

BUREAU OF LAND MANAGEMENT
43 CFR PART 3160

Federal Register / Vol 58, No. 172
Wednesday, September 8, 1993
Effective date: October 8, 1993

Onshore Oil and Gas Operations; Federal and Indian Oil & Gas Leases;
Onshore Oil and Gas Order No. 7: Disposal of Produced Water

- I. Introduction
 - A. Authority.
 - B. Purpose.
 - C. Scope.
- II. Definitions
- III. Requirements.
 - A. General Requirements.
 - B. Application Authority.
 - C. Informational Requirements for Injection Wells.
 - D. Informational Requirements for Pits.
 - E. Design Requires for Pits.
 - F. Construction and Maintenance Requirements for Pits.
 - G. Other Disposal Methods.
 - H. Reporting Requirements for Disposal Facilities.
- IV. Variances from Requirements or Minimum Standards.

Attachment.

- I. Figures.

Onshore Oil and Gas Order No. 7

Disposal of Produced Water

- I. Introduction

A. *Authority.* This Order is established pursuant to the authority granted to the Secretary of the Interior by various Federal and Indian mineral leasing statutes and the Federal Oil and Gas Royalty Management Act of 1982. Said authority has been delegated to the Bureau of Land Management and is implemented by the onshore oil and gas operating regulations contained in 43 CFR part 3160. Section 3164.1 thereof specifically authorizes the Director to issues Onshore Oil and Gas Orders when necessary to implement and supplement the operating regulations and provides that all such Order shall be binding on the operators of Federal and restricted Indian oil

and gas leases which have been, or may hereafter, be issued.

As directed by the Federal Onshore Oil and Gas Leasing Reform Act of 1987, for National Forest lands the Secretary of Agriculture shall regulate all surface-disturbing activities and shall determine reclamation and other actions required in the interest of conservation of surface resource. Specific authority for the provisions contained in this Order is found at section 3162.3, Conduct of Operations; section 3162.5, Environment and Safety; and Subpart 3163, Noncompliance and Assessments.

B. *Purpose.* This Order supersedes Notice to Lessees and Operators of Federal and Indian Oil and Gas Leases (NTL-2B), Disposal of Produced Water. The purpose of this Order is to specify informational and procedural requirements for submittal of an application for the disposal of produced water, and the design, construction and maintenance requirements for pits as well as the minimum standards necessary to satisfy the requirements and procedures for seeking a variance from the minimum standards. Also set forth in this Order are specific acts of noncompliance, corrective actions required and the abatement period allowed for correction.

C. *Scope.* This Order is applicable to disposal of produced water from completed wells on Federal and Indian (except Osage) oil and gas leases. It does not apply to approval of disposal facilities on lands other than Federal and Indian lands. Separate approval under this Order is not required if the method of disposal has been covered under an enhanced recovery project approved by the authorized officer.

[58 FR 58506, Nov. 2, 1993]

II. Definitions

The following definitions are used in conjunction with the issuance of this Order.

A. *Authorized officer* means any employee of the Bureau of Land Management authorized to perform duties described in 43 CFR Groups 3000 and 3100.

B. *Federal lands* means all lands and interests in lands owned by the United States which are subject to the mineral leasing laws, including mineral resource or nonmineral estates reserved to the United States in the conveyance of a surface or nonmineral estate.

C. *Free-board* means the vertical distance from the top of the fluid surface to the lowest point on the top of the dike surrounding the pit.

D. *Injection well* means a well used for the disposal of produced water or for enhanced recovery operations.

E. *Lease* means any contract, profit share arrangement, joint venture, or other agreement issued or approved by the United States under a mineral leasing law that authorized exploration for, extraction of, or removal of oil or gas (see 43 CFR 3160.0-5).

F. *Lessee* means a person or entity holding record title in a lease issued by the United States (see 43 CFR 3160.0-5).

G. *Lined pit* means an excavated and/or bermed area that is required to be lined with natural or manmade material that will prevent seepage. Such pit shall also include a leak detection system.

H. *Unlined* pit means an excavated and/or bermed area that is not required to be lined, or any pit that is lined but does not contain a leak detection system.

I. *Major violation* means noncompliance that causes or threatens immediate, substantial, and adverse impacts on public health and safety, the environment, production accountability, or royalty income (see 43 CFR 3160.0-5).

J. *Minor violation* means noncompliance that does not rise to the level of a "major violation" (see 43 CFR 3160.0-5).

K. *National Pollutant Discharge Elimination System (NPDES)* means a program administered by the Environmental Agency or primary State that requires permits for the discharge of pollutants from any point source into navigable water of the United States.

L. *Operator* means any person or entity, including but not limited to the lessee or operating rights owner, who has stated in writing to the authorized officer that it is responsible under the terms and conditions of the lease for the operations conducted on the leased lands or a portion thereof (see 43 CFR 3610.0-5).

M. *Produced water* means water produced in conjunction with oil and gas production.

N. *Toxic constituents* means substances in produced water that when found in toxic concentration specified by Federal or State regulations have harmful effects in plant or animal life. These substance include but are not limited to arsenic (As), barium (Ba), cadmium (Cd), hexavalent chromium (hCr), total chromium (tCr), lead (Pb), mercury (Hg), zinc (Zn), selenium (Se), benzene, toluene, ethylbenzene, and xylenes, as defined in 40 CFR 261.

O. *Underground Injection Control (UIC)* program means a program by administered by the EPA, primary State, or Indian Tribe under the Safe Drinking Water Act to ensure that subsurface injection does not endanger underground sources of drinking water.

[58 FR 58506, Nov. 2, 1993]

III. Requirements

A. *General Requirements*

Operators of onshore Federal and Indian oil and gas leases shall comply with the requirements and standards this Order for the protection of surface and subsurface resources. Except as provided under section III.D.3 of this Order, the operator may not dispose of produced water unless and until approval is obtained from the authorized officer. All produced water from Federal/Indian leases must be disposed of by (1) injection into the subsurface; (2) discharging into pits; or (3) other acceptable methods approved by the authorized officer, including surface discharge under NPDES permit. Injection is generally the preferred method of disposal. Operators are encouraged to contact the appropriate authorized officer before filing an application for disposal of produced water so that the operator may be apprised of any existing agreements outlining cooperative procedures between the Bureau of Land Management and either the State/Indian Tribe or the Environmental Protection Agency concerning Underground Injection Control permits for injection wells, and of any potentially significant adverse effects on surface and/or subsurface resources. The approval of the Environmental Protection Agency or a State/Tribe shall not be considered as granting approval to dispose of produced water from leased

Federal or Indian lands until and unless BLM approval is obtained. Applications filed pursuant to NTL-2B and still pending approval shall be supplemented or resubmitted if they do not meet the requirements and standards of this Order. The disposal methods shall be approved in writing by the authorized officer regardless of the physical location of the disposal facility. Existing NTL-2B approvals will remain valid. However, upon written justification, the authorized officer may impose additional conditions or revoke any previously approved disposal permit, if the authorized officer, for example, finds that an existing facility is creating environmental problems, or that an unlined pit should be lined, because the quality of the produced water has changed so that it no longer meets the standards for unlined pits.

Unless prohibited by the authorized officer, produced water from newly completed wells may be temporarily disposed of into pits for a period of up to 90 days, if the use of the pit was approved as a part of an application for permit to drill. Any extension of time beyond this period requires documented approval by the authorized officer.

Upon receipt of a completed application the authorized officer shall take one of the following actions within 30 days: (1) Approve the application as submitted or with appropriate modification or conditions; (2) return the application and advise the applicant in writing of the reasons for disapproval; or (3) advise the applicant in writing of the reasons for delay and the expected final action date.

If the approval for a disposal facility, e.g., commercial pit or Class II injection well, is revoked or suspended by the permitting agencies such as the Environmental Protection Agency or the primacy State, the BLM water disposal approval is immediately terminated and the operator is required to propose an alternative disposal method.

B. *Application and Approval Authority*

1. *On-lease Disposal.* For water produced from a Federal/Indian lease and disposed of on the same Federal/Indian lease, or on other committed Federal/Indian leases if in a unit or communitized area, the approval of the disposal method is usually granted in conjunction with the approval for the disposal facilities. An example would be approval of a proposal to drill an injection well to be used for the disposal of produced water from a well or wells on the same lease.
 - a. *Disposal of water in injection wells.* When approval is requested for onlease disposal of produced water into an injection well, the operator shall submit a Sundry Notice, Form 3160-5. Information submitted in support of obtaining the Underground Injection Control permit shall be accepted by the authorized officer in approving disposal method, provided the information submitted in support of such a permit satisfies all applicable Bureau of Land Management statutory responsibilities (including but not limited to drilling safety, down hole integrity, and protection of mineral and surface resources) and requirements. If the authorized officer has on file a copy of the approval for the receiving facilities, he/she may determine that a reference to that document is sufficient.
 - b. *Disposal of water in pits.* When approval is requested for disposal of produced water in a lined or unlined pit, the operator shall submit a Sundry Notice, Form

3160-5. The operator shall comply with all the applicable Bureau of Land Management requirements and standards for pits established in this Order. On National Forest lands, where the proposed pit location creates new surface disturbance, the authorized officer shall not approve the proposal without the prior approval of the Forest Service.

[58 FR 58506, Nov. 2, 1993]

2. *Off-lease Disposal*

- a. *On leased or unleased Federal/Indian lands.* The purpose of the off-lease disposal approval process is to ensure that the removal of the produced water from a Federal or Indian oil and gas lease is proper and that the water is disposed of in an authorized facility. Therefore, the operator shall submit a Sundry Notice, Form 3160-5, for removal of the water together with a copy of the authorization for the disposal facility. If the authorized officer has a copy of the approval for the receiving facilities on file, he/she may determine that a reference to that document is sufficient. Where an associated right-of-way authorization is required, the information for the right-of-way authorization may be incorporated in the Sundry Notice, and the Bureau of Land Management will process both authorizations simultaneously for Bureau lands.
 - i. *Disposal of water in injection wells.* When approval is requested for removing water that is produced from wells on leased Federal or Indian lands and that is to be injected into a well located on another lease or unleased Federal lands, the operator shall submit to the authorized officer a Sundry Notice, Form 3160-5, along with a copy of the Underground Injection Control permit issued to the operator of the injection well, unless the well is authorized by rule under 40 CFR part 144.
 - ii. *Disposal of water in pits.* When approval is requested for removing water that is produced from wells on leased Federal or Indian lands and is to be disposed of into a lined or unlined pit located on another lease or unleased Federal lands, the operator shall submit to the authorized officer a Sundry Notice, Form 3160-5.
 - iii. *Right-of-way procedures.* The operator of the injection well or pit is required to have an authorization from the Bureau of Land Management for disposing of the water into the pit or well, under Title V of FLPMA and 43 CFR Part 2800, or a similar authorization from the responsible surface management agency. In transporting the produced water from the lease to the pit or injection well, e.g., building a road or laying a pipeline, a right-of-way authorization under Title V of FLPMA and 43 CFR Part 2800 from the Bureau of Land Management or a similar permit from the responsible surface management agency also shall be obtained by the operator of the pit or any injection well or other responsible party.

- b. *Disposal of water on State and privately- owned lands.*
- i. *Disposal of water in injection wells.* When approval is requested for removing water that is produced from wells on leased Federal or Indian lands and that is to be injected into a well located on State or privately-owned lands, the operator shall submit to the authorized officer, in addition to a Sundry Notice, Form 3160-5, a copy of the Underground Injection Control permit issued for the injection well by Environmental Protection Agency or the State where the State the achieved primacy. Submittal of the Underground Injection Control permit will be accepted by the authorized officer and approval will be granted for the removal of the produced water unless the authorized officer states in writing that such approval will have adverse effects on the Federal/Indian lands or public health and safety.
 - ii. *Disposal of water in pits.* When approval is requested for removing water that is produced from wells on leased Federal and/or Indian lands and is to be disposed of into a pit located on State or privately-owned lands, the operator shall submit to the authorized officer, in addition to a Sundry Notice, Form 3160-5, a copy of the permit issued for the pit by the State or any other regulatory agency, if required, for disposal in such pit. Submittal of the permit will be accepted by the authorized officer and approval will be granted for removal of the produced water unless the authorized officer states in writing that such approval will have adverse effects on the Federal/Indian lands or public health and safety. If such a permit is not issued by the State or other regulatory agency, the requested removal of the produced water from leased Federal or Indian lands will be denied.
 - iii. *Right-of-way procedures.* If the water produced from wells on leased Federal and/ or Indian lands, and to be disposed of at a location on State or privately-owned lands, will be transported over off-lease Federal or Indian lands, the operator of the disposal facility or other responsible party shall have an authorization from the Bureau of Land Management under Title V of FLPMA and 43 CFR part 2800, or a similar authorization from the responsible surface management agency.

C. *Informational requirements for injection wells.*

For an injection well proposed on Federal or Indian leases, the operator shall obtain an Underground Injection Control(UIC) permit pursuant to 40 CFR parts 144 and 146 from the Environmental Protection Agency or the State/Tribe where the State/Tribe has achieved primacy. The operator shall also comply with the pertinent procedural and informational requirements for Application for Permit to Drill or Sundry Notice as set forth In Onshore Oil and Gas Order No. 1. The injection well shall be designed and drilled or conditioned in accordance with the requirements and standards described in Order No. 2 and pertinent NTLs, as well as the Underground Injection Control permit.

D. *Informational requirements for pits.*

Operators who request approval for disposal of produced water into a lined or unlined pit shall file an application on a Sundry Notice, Form 3160-5, and identify the operator's field representative by name, address and telephone number, and the source of the produced water. Sources of produced water shall be identified by facility, lease number, well number and name, and legal description of well location. All samples for water analysis shall be taken at the current discharge point. A reclamation plan detailing the procedures expected to be followed for closure of the pit and the contouring and revegetating of the site shall be submitted prior to pit abandonment. If requested by the authorized officer, a contingency plan to deal with specific anticipated emergency situations shall be submitted as provided for in 43 CFR 3162.5-1(d).

[58 FR 58506, Nov. 2, 1993]

1. *Lined pits.* The authorized officer shall not consider for approval an application for disposal into lined pits on Federal/Indian leases unless the operator also provides the following information:
 - a. A map and drawings of the site on a suitable scale that show the pit dimension, cross section, side slopes, leak detection system, and location relative to other site facilities.
 - b. The daily quantity of water to be disposed of (maximum daily quantity shall be cited if major fluctuations are anticipated) and a water analysis (unless waived by the authorized officer as unnecessary) that includes the concentrations of chlorides, sulfates, pH, Total Dissolved Solids (TDS), and toxic constituents that the authorized officer reasonably believes to be present.
 - c. Criteria used to determine the pit size, which includes a minimum of 2 feet of free-board.
 - d. The average monthly evaporation and average monthly precipitation for the area.
 - e. The method and schedule for periodic disposal of precipitated solids and a copy of the appropriate disposal permit, if any.
 - f. The type, thickness, and life span of material to be used for lining the pit and the method of installation. The manufacturer's guidebook and information for the product shall be included, if available.

[58 FR 58506, Nov. 2, 1993]

2. *Unlined pits.*

Application for disposal into unlined pits may be considered for approval by the authorized officer where the application of the operator shows that such disposal meets one or more of the following criteria:

- i. The water to be disposed of has an annual average TDS concentration equal to or less than that of the existing water to be protected, provided that the level of any toxic constituents in the produced water does not exceed established State or Federal standards for protection of surface and/or ground water.
- ii. All, or a substantial part, of the produced water is being used for beneficial

purposes and meets minimum water quality standards for such uses. For example, usage of produced water for purposes such as irrigation and livestock or wildlife watering shall be considered as beneficial.

- iii. (A) The water to be disposed of will not degrade the quality of surface or subsurface waters in the area;
 - (B) The surface and subsurface waters contain TDS above 10,000 ppm, or toxic constituents in high concentrations; or
 - (C) The surface and subsurface waters are of such poor quality or small quantity as to eliminate any practical use thereof.
 - iv. That the volume of water to be disposed of per disposal facility does not exceed an average of 5 barrels per day on a monthly basis.
- b. Operators applying for disposal into an unlined pit shall also submit the following information, as appropriate:
- (i) Applications for disposal into unlined pits that meet the criteria in a., above, shall include:
 - (A) A map and drawings of the site on a suitable scale that show the pit dimension, cross section, side slopes, size, and location relative to other site facilities.
 - (B) The daily quantity of water to be disposed of and a water analysis that includes Total Dissolved Solids (in ppm), pH, oil and grease content, the concentrations of chlorides and sulfates, and other parameters or constituents toxic to animal or plant life as reasonably prescribed by the authorized officer. The applicant should also indicate any effort or interaction of produced water with any water resources present at or near the surface and other known mineral deposits. For applications submitted under criterion a.iv., above, the water quality analysis is not needed unless requested by the authorized officer.
 - (C) The average monthly evaporation and the average monthly precipitation for the area. For applications submitted under criterion a.iv., average annual data will be acceptable.
 - (D) The estimated percolation rate on soil characteristics under and adjacent to the pit. In some cases the authorized officer may require percolation tests using accepted test procedures.
 - (E) Estimated depth and areal extent of the shallowest known aquifer with TDS less than 10,000 ppm, and the depth and extent of any known mineral deposits in the area.
 - ii. Where beneficial use (criterion a.ii., above) is the basis for the application, the justification submitted shall also contain written the confirmation from the user(s).
 - iii. If the application is made on the basis that surface and subsurface waters will not be adversely affected by disposal in an unlined pit (criterion a.iii., above), the justification shall also include the following additional information:

- (A) Map of the site showing the location of surface waters, water wells, and water disposal facilities within 1 mile of the proposed disposal facility.
- (B) Average concentration of TDS (in ppm) of all surface and subsurface waters within the 1-mile radius that might be affected by the proposed disposal.
- (C) Reasonable geologic and hydrologic evidence that shows the proposed disposal method will not adversely affect existing water quality or major uses of such waters, and identifies the presence of any impermeable barrier(s), as necessary.
- (D) A copy of any State order or other authorization granted as a result of a public hearing that is pertinent to the authorized officer's consideration of the application.

3. *Emergency pits.*

Application for a permanent pit (lined or unlined) to be used for anticipated emergency purposes shall be submitted by the operator on a Sundry Notice, Form 3160-5, for approval by the authorized officer, unless it has been approved in conjunction with a previously approved operational activity. Design criteria for an emergency pit will be established by the authorized officer on a case by case basis. Any emergency use of pits shall be reported in accordance with NTL-3A or subsequent replacement Order procedures, and the pit shall be emptied and the liquids disposed of in accordance with applicable State and/or Federal regulations within 48 hours following its use, unless such time is extended by the authorized officer.

E. *Design requirements for pits*

1. Pits shall be designed to meet the following requirements and minimum standards. For unlined pits approved under criterion D.2.a.iv, requirements d. and e., below, do not apply.
 - a. As much as practical, the pit shall be located on level ground and away from established drainage patterns, including intermittent/ephemeral drainage ways, and unstable ground or depressions in the area.
 - b. The pit shall have adequate storage capacity for safe containment of all produced water, even in those periods when evaporation rates are at a minimum. The design shall provide for a minimum of 2 feet of free-board.
 - c. The pit shall be fenced or enclosed to prevent access by livestock, wildlife, and unauthorized personnel. If necessary, the pit shall be equipped to deter entry by birds. Fences shall not be constructed on the levees. Figure 1 shows an example of an acceptable fence design.
 - d. The pit levees are to be constructed so that the inside grade of the levee is no steeper than 1 (vertical):2 (horizontal), and the outside grade no steeper than 1:3.
 - e. The top of levees shall be level and least 18 inches wide.
 - f. The pit location shall be reclaimed pursuant to the requirements and standards of

- the surface management agency. On a spilt estate (private surface, Federal mineral) a surface owner's release statement or form is acceptable.
2. Lined pits shall be designed to meet following requirements and minimum standards in addition to those specified above:
 - a. The material used in lining pits shall be impervious. It shall be resistant to weather, sunlight, hydrocarbons, aqueous acids, alkalies, salt, fungi, or other substances likely to be contained in the produced water.
 - b. If rigid materials are used, leak-proof expansion joints shall be provided, or the material shall be of sufficient thickness and length to withstand expansion without cracking, contraction, and settling movements in the underlying earth. Semi-rigid liners such as compacted bentonite or clay may be used provided that, considering the thickness of the lining material chosen and its degree of permeability, the liner is impervious for the expected period of use. Figure 2 shows examples of acceptable standards for concrete, asphalt, and bentonite/clay liners.
 - c. If flexible membrane materials are used, they shall have adequate resistance to tears or punctures. Figures 3 gives an example of acceptable standards for installation of the flexible membrane.
 - d. Lined pits shall have an underlying gravel-filled sump and lateral system or other suitable devices for the detection of leaks. Examples of the acceptable design of the leak detection system are shown in Figure 4 and Figure 5.
 3. Failure to design the pit to meet the above requirements and minimum standards will result in disapproval of the proposal or a requirement that it be modified unless a request for variance is approved by the authorized officer.

F. Construction and maintain requirements for pits

Inspections will be conducted according to the following requirements and minimum standards during the construction and operation of the pit. Failure to meet the requirements and standards may result in issuance of an Incident of Noncompliance (INC) for the violation. The gravity of the violation, corrective actions, and the normal abatement period allowed are specified for each of the requirements/standards.

1. Any disposal method that has not been approved shall be considered an incident of noncompliance and may result in the issuance of a shut-in order, assessments, or penalties pursuant to 43 CFR part 3163 until an acceptable disposal method is provided and approved by the authorized officer.

Violation: Minor: If it causes no significant environmental damages or effects.
 Major: If it causes or threatens immediate, substantial and adverse impact on public health and safety, the environment, production accountability, or royalty income.

Corrective action: Minor: Submit acceptable application.
 Major: Shut-in, take corrective action to repair or replace damages according to instructions of authorized officer.

Abatement periods: Minor. 1 to 20 days or as directed by authorized officer.
Major: Within 10 days.

[58 FR 58506, Nov.2, 1993]

2. The operator shall notify the authorized officer to inspect the leak detection system at least 2 business days prior to the installation of the pit liner.

Violation: Minor.

Corrective action: Require verification of its installation.

Abatement period: Prior to use of pit.

3. At least 2 business days prior to its use, the operator shall notify the authorized officer of completion the pit construction, so that the authorized officer may verify that the pit has been constructed in accordance with the approved plan.

For failure to notify:

Violation: Minor.

Corrective action: Not applicable.

For failure to construct in accordance with the approved plan

Violation: Minor, unless Major by definition.

Corrective action: The authorized officer may shut-in operations and require corrections to comply with the plan or require amendment of the plan.

Abatement period: 1 to 20 days depending on the severity of the violation and the degree of difficulty to correct, if the pit is in use.

4. Lined pit shall be maintained and operated to prevent unauthorized subsurface discharge of water.

Violation: Usually Minor, unless Major as result of discharge.

Corrective action: Repair/replace liner and possibly shut in operations.

Abatement period: 1 to 20 days depending on the onsite situation.

5. The pit shall be maintained as designed to prevent entrance of surfaces water by providing adequate surface drainage away from the pit.

Violation: Minor.

Corrective action: Provide surface drainage.

Abatement period: Within 20 days.

6. The pit shall be maintained and operated to prevent unauthorized surface discharge of water.

Violation: Usually Minor, unless discharge results in Major.

Corrective action: Clean up if spill occurs, and reduce the water level to maintain the 2 feet of free-board; shut-in operations, if required by authorized officer.

Abatement period: 1 to 20 days depending upon the onsite situation.

7. The outside walls of the pit levee shall be maintained as designed to minimize erosion.

Violation: Minor.

Corrective action: Necessary repair.

Abatement period: Within 20 days.

8. The pit shall be kept reasonably free from surface accumulation of liquid hydrocarbons that would retard evaporation.

Violation: Minor.

Corrective action: Clean-up, and may require skimmer pits, settling tanks, or other suitable equipment.

Abatement period: Within 20 days.

9. The operator shall inspect the leak detection system at least once a month or more often if required by the authorized Officer in appropriate circumstances. The record of inspection shall describe the result of the inspection by date and shall be kept and made available to the authorized officer upon request.

Violation: Minor.

Corrective action: Commence the required routine inspection and recordkeeping.

Abatement period: Within 30 days.

[58 FR 58506, Nov. 2, 1993]

10. Prior to pit abandonment and reclamation, the operator shall submit a Sundry Notice for approval by the authorized officer, if not previously approved.

Violation: Minor.

Corrective action: Cease operations and file an application.

Abatement period: Within 10 days.

11. When change in the quantity and/or quality of the water disposed into an unlined pit causes the pit no longer to meet the unlined pit criteria listed under section D.2.a., the operator shall submit a Sundry Notice amending the pit design for approval by the authorized officer.

Violation: Minor unless the resulting damage is Major.

Corrective action: Submit the required amendment; shut-in operations if determined by the authorized officer to be Major.

Abatement period: As specified by the authorized officer.

G. Other disposal methods

1. Surface discharge under NPDES permit. The person applying to use this disposal method shall furnish a copy of the NPDES permit issued by the EPA or the

primacy State, a current water quality analysis and a Sundry Notice, Form 3160-5, describing site facilities (e.g., retention ponds, skimmer pits and equipment, tanks, and any additional surface disturbance). Operations from the point of origin to the point of discharge under the jurisdiction of the BLM. Operations from the point of discharge downstream are under the jurisdiction of EPA or the primacy State.

2. Use of existing commercial pits designed for containment of produced water or tanks in lieu of pits.
3. New technology or any other proposal meeting the objective of this Order that the authorized officer deems acceptable and that meets the requirements of State and Federal laws and regulations.

H. *Reporting requirements for disposal facilities*

All unauthorized discharge or spills from disposal facilities on Federal/Indian leases shall be reported to the authorized officer in accordance with the provisions of NTL-3A or subsequent replacement Order.

Violation: Minor unless resulting damage is major.

Corrective action: Submit the required report.

Abatement period: As specified by the authorized officer.

IV. **Variances from Requirements or Standards Minimum Standards**

An operator may request that the authorized officer approve a variance from any of the requirements or minimum standards prescribed in Section III. of this Order. All such requests shall be submitted in writing to the appropriate authorized officer and provide information as to the circumstances that warrant approval of the variance(s) requested and the proposed alternative means by which the requirements or related minimum standard(s) will be satisfied. The authorized officer, after considering all relevant factors, will approve the requested variance(s) if it is determine that the proposed alternative(s) meet or exceed the objectives of the applicable minimum standard(s); or if the authorized officer determines that the exemption of the requirement is justified. Variances granted BLM under this section shall be limited to proposals and requirements under BLM statutory and/or regulatory authority only, and shall not be construed as granting variance to regulations under EPA, State, or Tribal authority.

[58 FR 58506, Nov. 2, 1993]

Attachments

CORNER CONSTRUCTION
(applicable to barbed or net type wire)

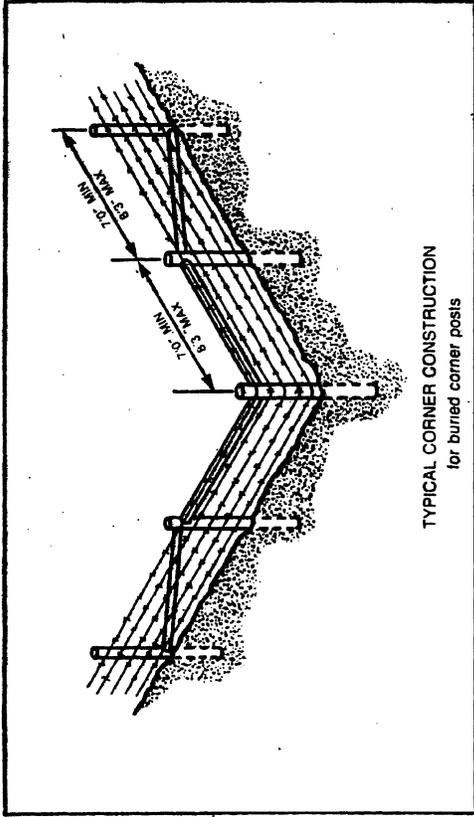

TYPICAL CORNER CONSTRUCTION
for corner post set in concrete

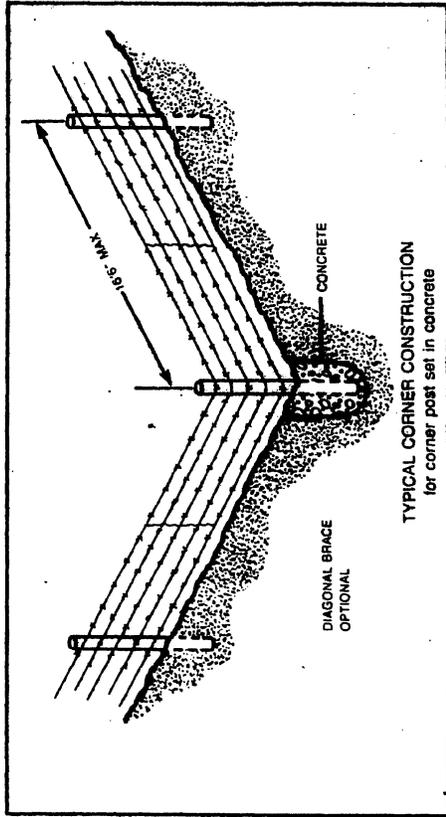

FENCE CONSTRUCTION

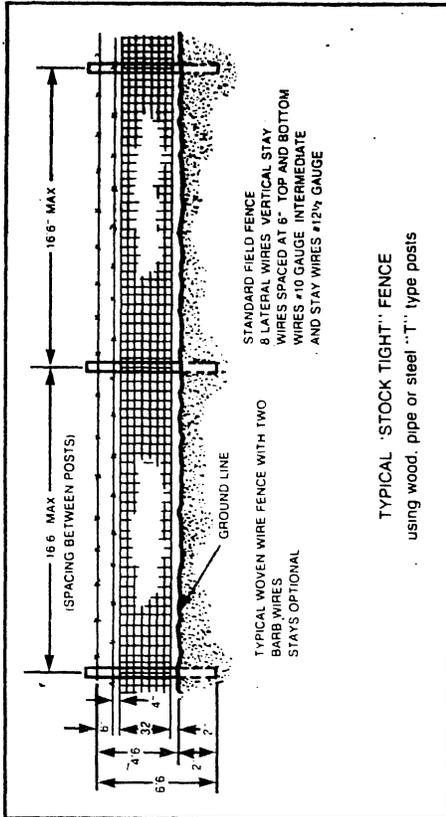
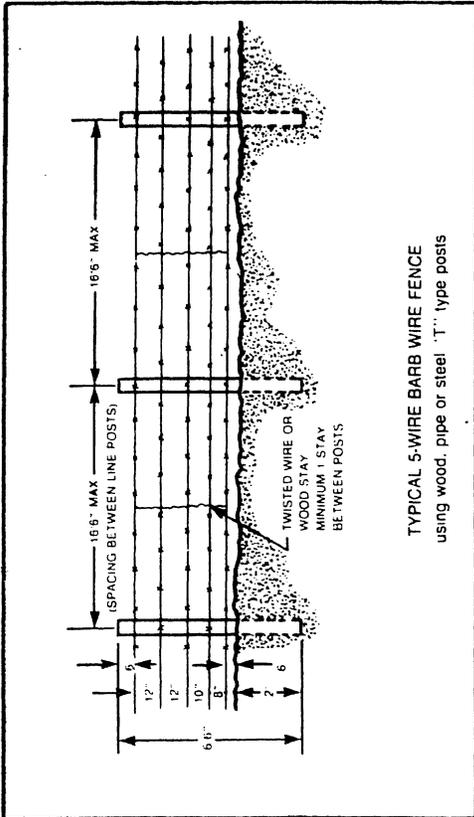

FIGURE 1. EXAMPLES FOR DESIGN AND CONSTRUCTION OF FENCE AND CORNER POSTS.

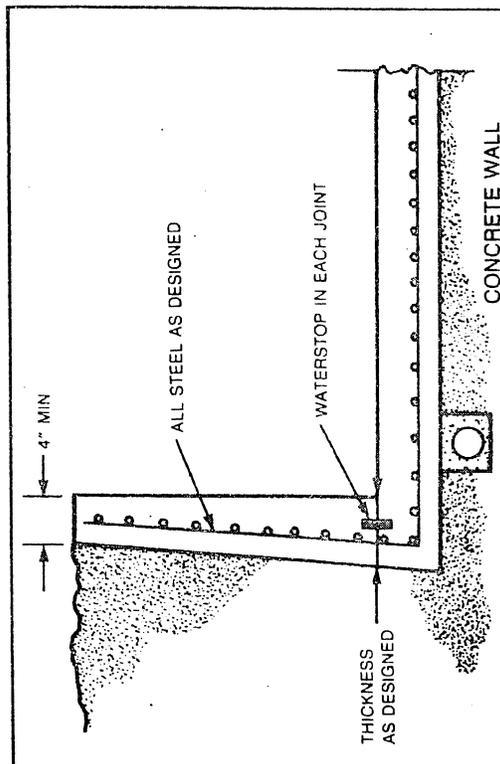
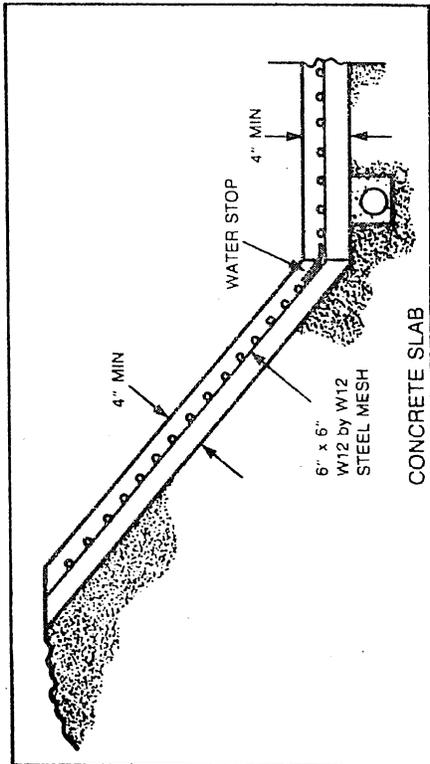
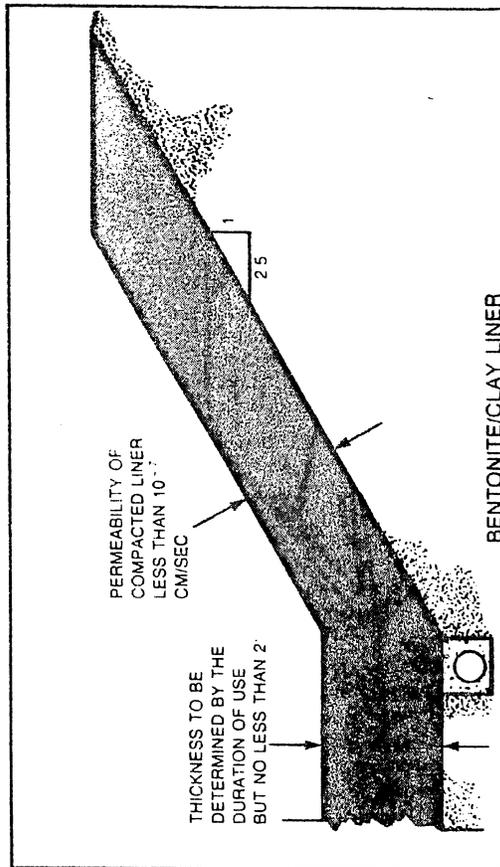
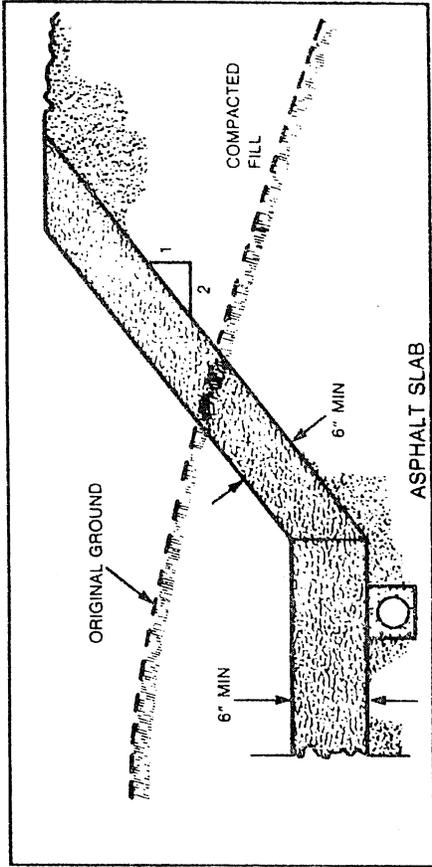
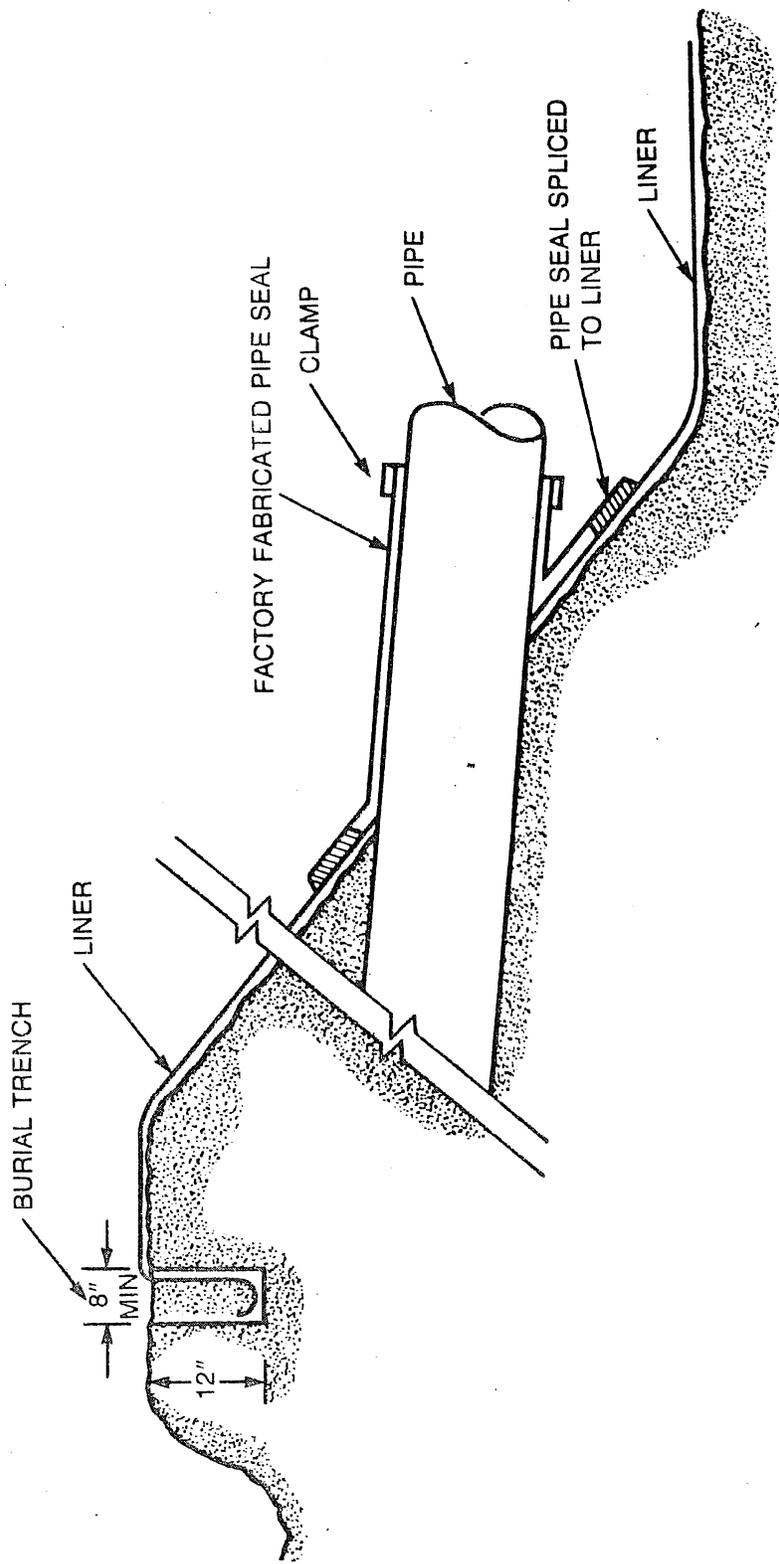

FIGURE 2. EXAMPLE OF ACCEPTABLE DESIGN FOR CONCRETE, ASPHALT AND BENTONITE/CLAY LINERS



LEAK DETECTION SYSTEM
NOT SHOWN

FIGURE 3. EXAMPLE OF ACCEPTABLE DESIGN FOR INSTALLATION OF A FLEXIBLE LINER.

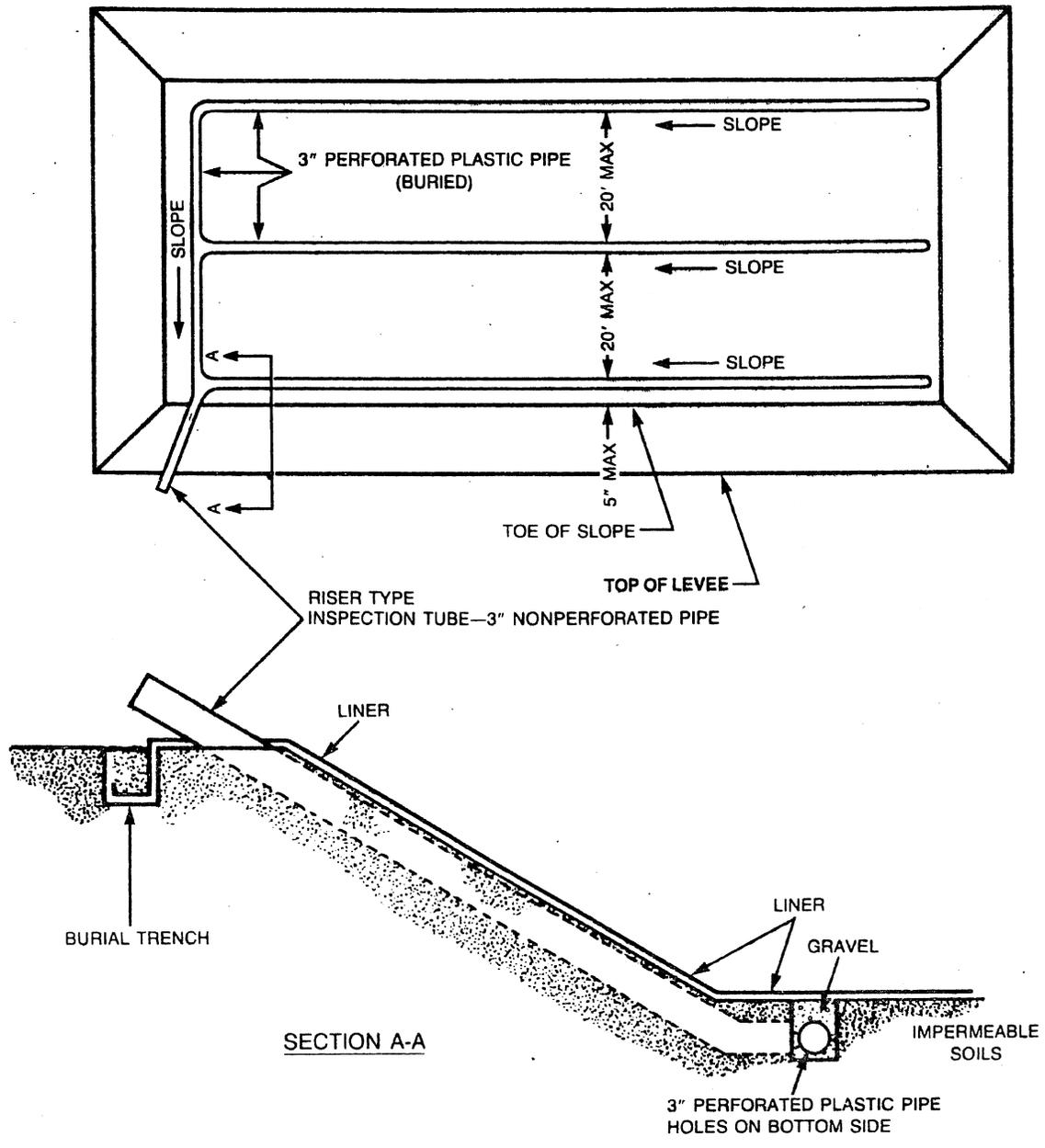

FIGURE 4. EXAMPLE OF A LEAK DETECTION SYSTEM FOR A LINED PIT CONSTRUCTED IN RELATIVELY IMPERMEABLE SOILS.

Attachment 1 - 4

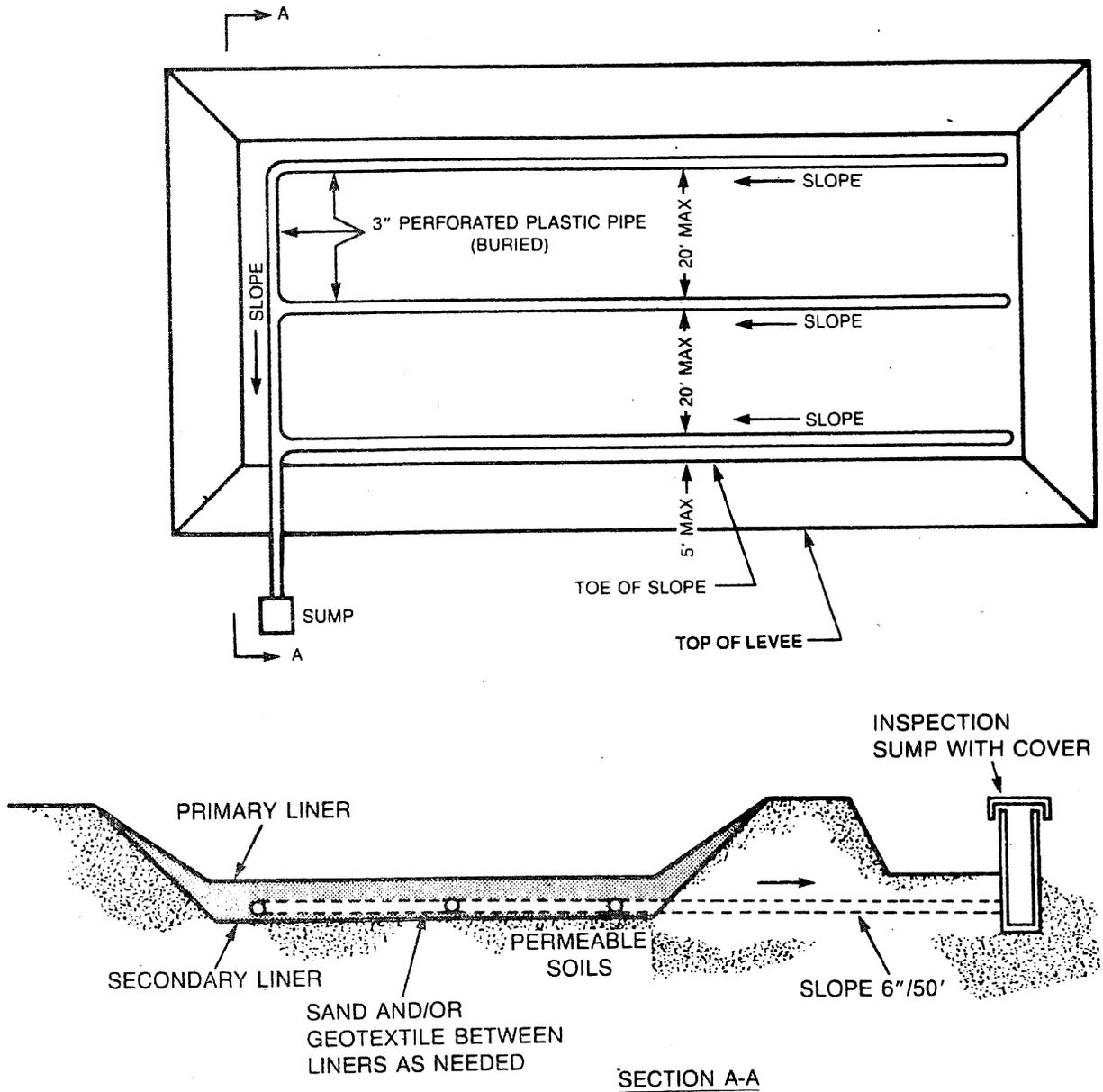

FIGURE 5. EXAMPLE OF A LEAK DETECTION SYSTEM FOR A LINED PIT CONSTRUCTED IN PERMEABLE SOILS.

Attachment 1 - 5